



Documentation générale

Le Mur Rideau CW50



www.tf-alu.fr

105, Ter Avenue du Général de Gaulle—33190 Gironde sur dropt

SOMMAIRE

◆ Profilés

- ⇒ Détail des profilésA01
- ⇒ Calcul de la flèche raidisseur et traverseA02

◆ Sections des nœudsB01-> B04

◆ Fabrication et montage

- ⇒ Possibilité d'assemblageC01 -> C02
- ⇒ Ancrage intermédiaireC03 -> C07
- ⇒ DilatationC08 -> C09
- ⇒ Renfort acierC10
- ⇒ Montage des emboutsC11
- ⇒ Assemblage traverseC12
- ⇒ Aperçu trame horizontaleC13 -> C14

Historique des mises à jours

Pour exemple : (la version originelle ne comporte aucune mention)

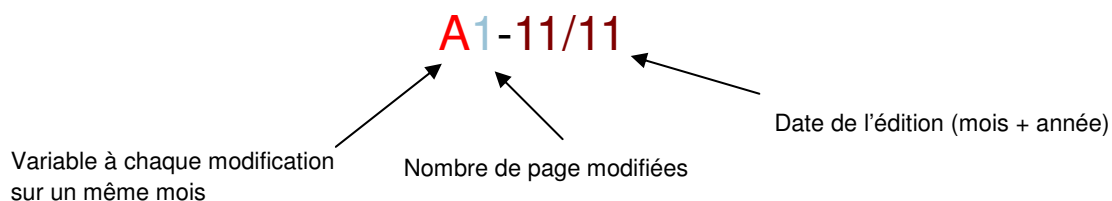

MONTANT ET TRAVERSE

Réf 400

ix : 13.974 cm⁴
 iy : 13.552 cm⁴

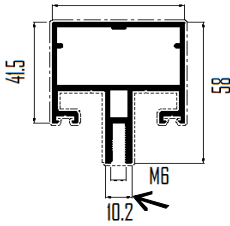

Réf 401

ix : 32.895 cm⁴
 iy : 17.716 cm⁴

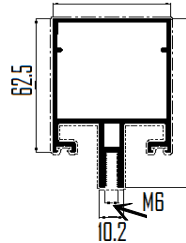

Réf 402

ix : 66.042 cm⁴
 iy : 22.243 cm⁴

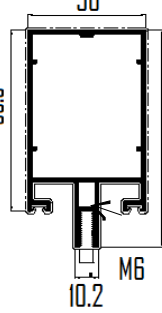

Réf 404

ix : 152.047 cm⁴
 iy : 30.142 cm⁴

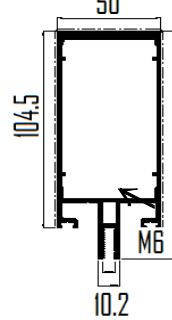

Réf 405

ix : 213.241 cm⁴
 iy : 35.003 cm⁴

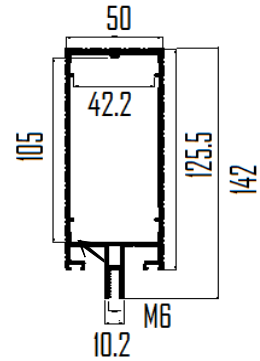

Réf 406

ix : 336.425 cm⁴
 iy : 40.680 cm⁴

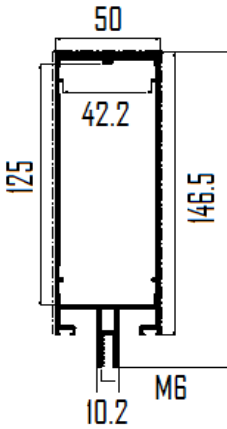

Réf 407

ix : 497.968 cm⁴
 iy : 46.432 cm⁴

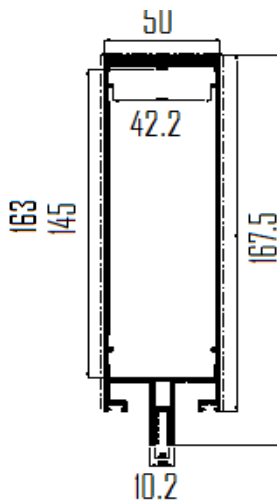

Réf 408

ix : 690.139 cm⁴
 iy : 59.365 cm⁴

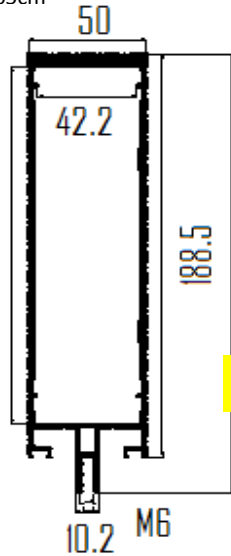

Réf 435

Réf 434

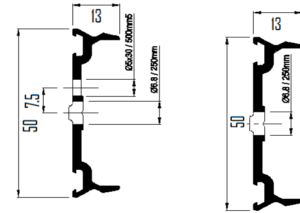

PIECE D'ECARTEMENT

Réf 581

Réf 582

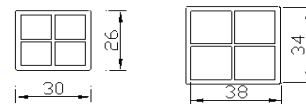

CAPOT

Réf 539

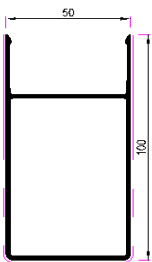

Réf 546

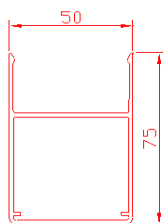

Réf 540

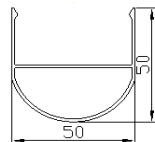

Réf 536

Réf 537

Réf 542

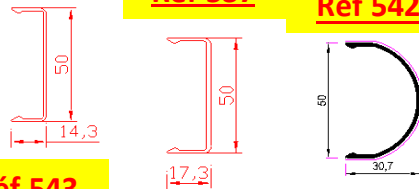

Réf 543



Réf 538

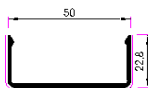

Réf 545

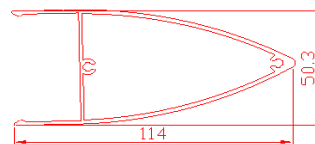
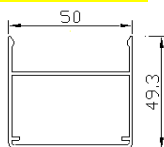

Calcul de la flèche raidisseur et traverse

LIBRES SUR 2 APPUIS

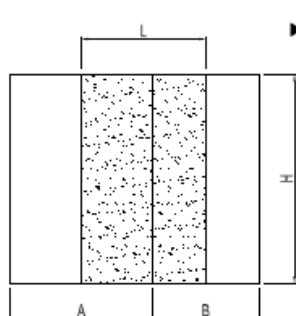

attaches / anchoring
raidisseur

$$f = \frac{5 \times p \times H^4}{384 \times E \times I}$$

$$f = \frac{H}{300} \text{ exprimée en cm / ln cm}$$

$$Q = \frac{H \times L \times P}{10\,000} \text{ exprimée en daN / ln daN}$$

$$p = \frac{Q}{H} \text{ exprimé en daN/cm / ln daN/cm}$$

P = pression de base en daN/m² (10Pa = 1 daN/m²)
 L = largeur de la charge en cm ($L = \frac{A+B}{2}$)
 H = distance entre les deux attaches du raidisseur en cm
 E = module d'élasticité en daN/cm²
 (pour l'aluminium E = 700 000 daN/cm²)
 I = Inertie du profil en cm⁴ / Inertia ln cm⁴
 1 daN = 1.02 kg

LIBRES SUR 3 APPUIS

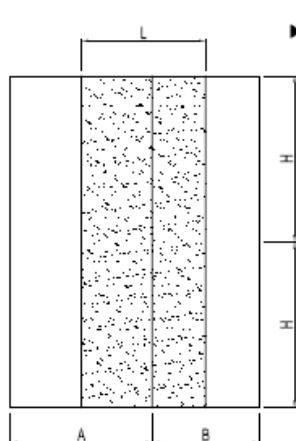

attaches / anchoring
raidisseur

$$f = \frac{p \times H^4}{185 \times E \times I}$$

$$f = \frac{H}{300} \text{ exprimée en cm}$$

$$Q = \frac{H \times L \times P}{10\,000} \text{ exprimée en daN}$$

$$p = \frac{Q}{H} \text{ exprimé en daN/cm}$$

P = pression de base en daN/m² (10Pa = 1 daN/m²)
 L = largeur de la charge en cm ($L = \frac{A+B}{2}$)
 H = distance entre les deux attaches du raidisseur en cm
 E = module d'élasticité en daN/cm²
 (pour l'aluminium E = 700 000 daN/cm²)
 I = Inertie du profil en cm⁴
 1 daN = 1.02 kg

LIMITE DE CHARGE VERTICALE

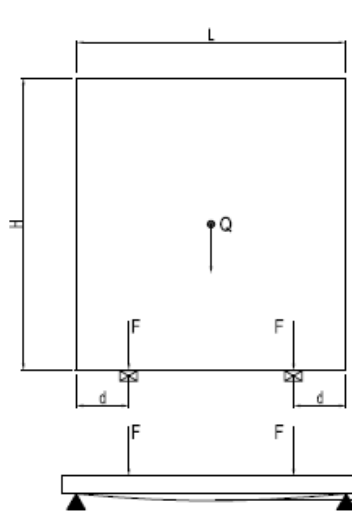

$$f = \frac{F \times d^4}{24 \times E \times I} \times (3L^2 - 4d^2)$$

$f < 0.3 \text{ cm}$
 F = charge ponctuelle $\frac{Q}{2}$
 $Q = \frac{L \times H}{10\,000} \times \text{poids/m}^2 \text{ de l'EdR}$
 $d = \frac{L}{10}$ en cm (voir DTU 39, calage d'EdR)

E = module d'élasticité en daN/cm²
 (pour l'aluminium E = 700 000 daN/cm²)
 L = largeur de l'EdR en cm
 H = hauteur de l'EdR en cm
 1 daN = 1.02 kg

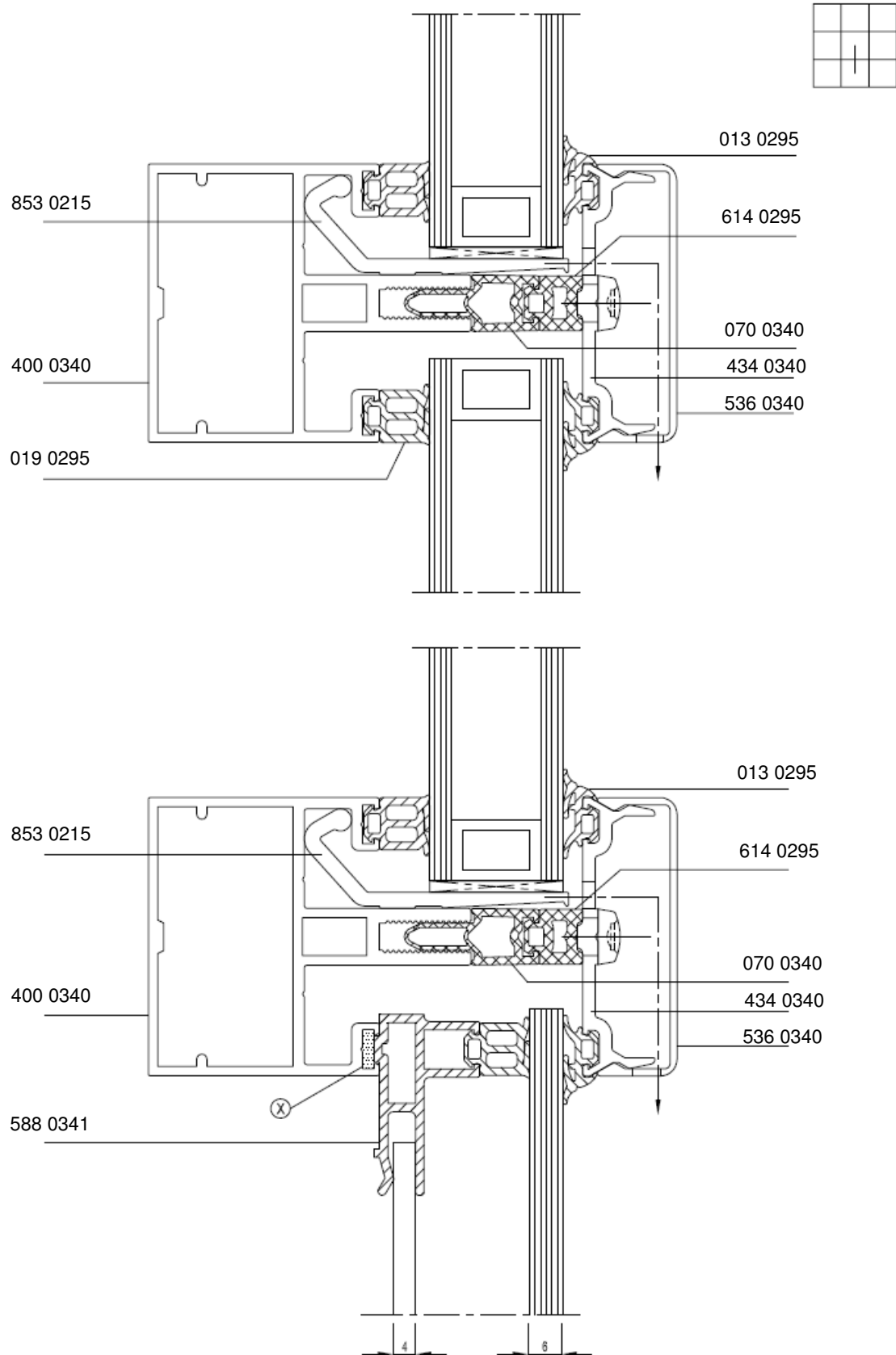

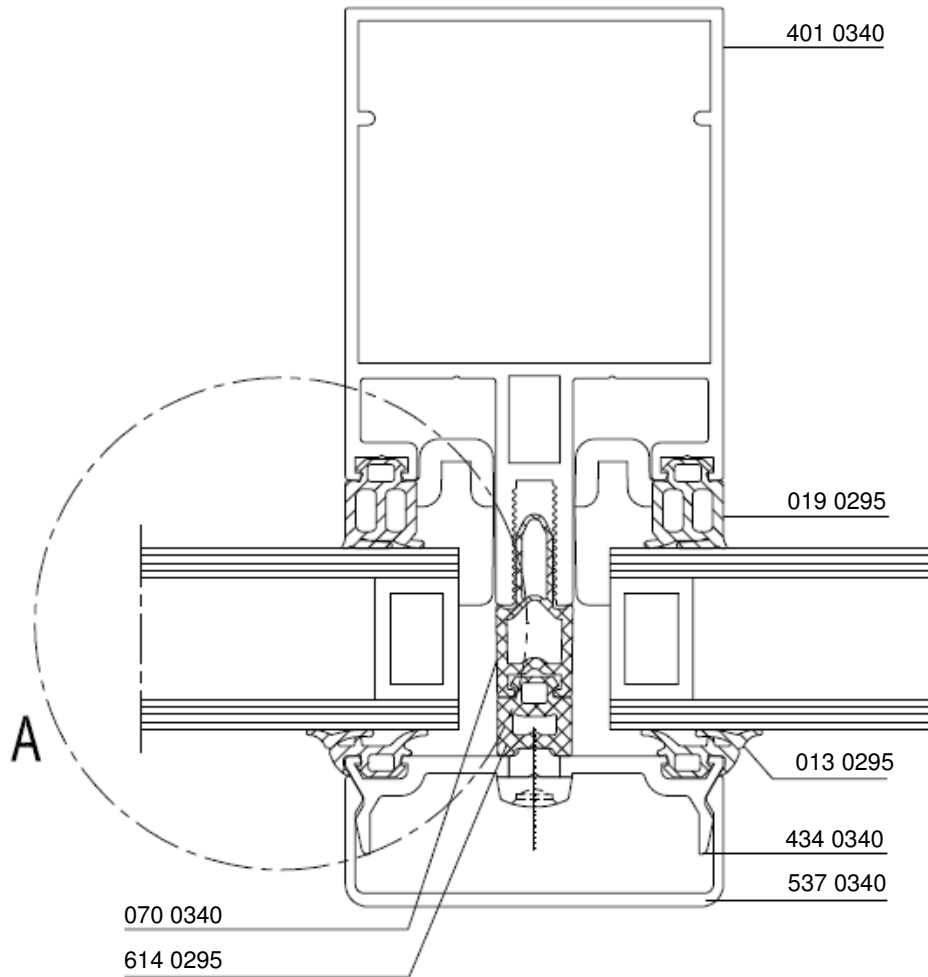

A

DETAIL A

165° - 180°

015 0295 / 017 0295
019 0295 / 021 0295

180°

015 0295 / 015 0295
019 0295 / 021 0295

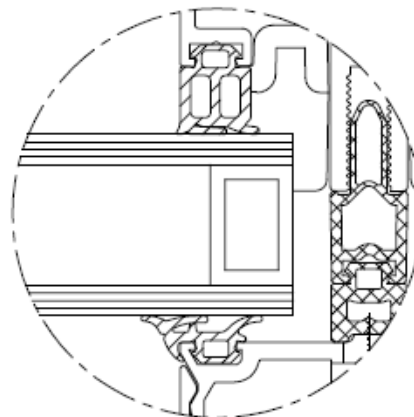
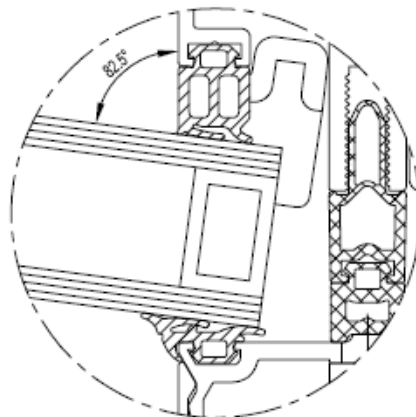

Nœuds

Trame horizontale

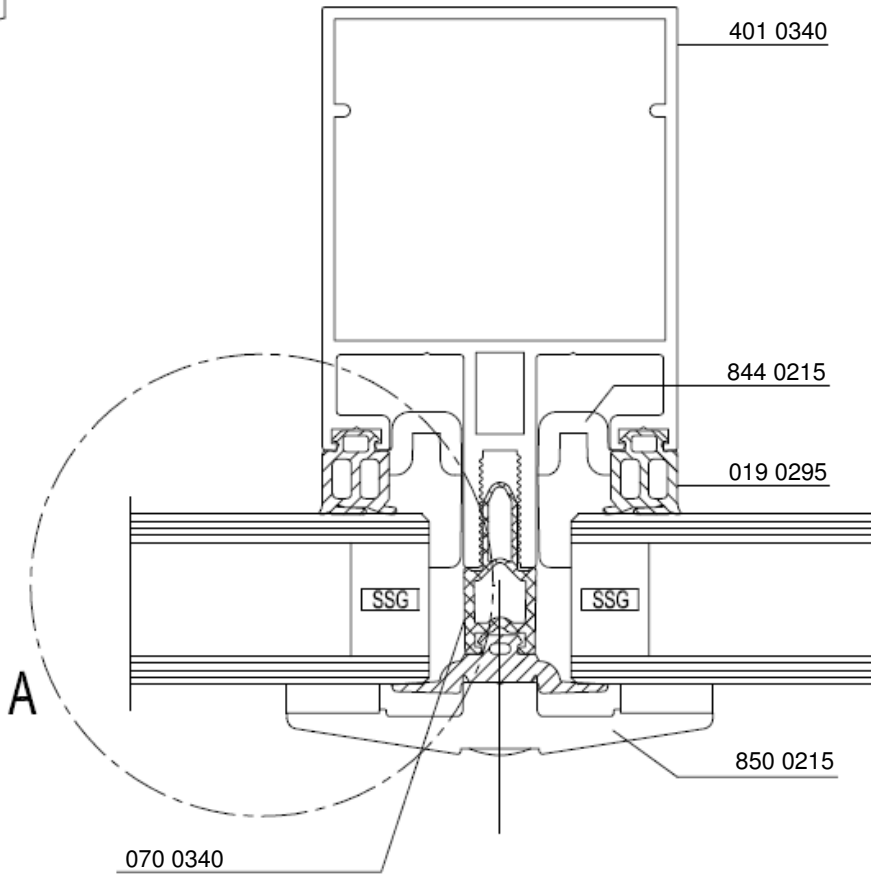
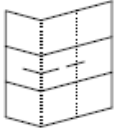

SSG Vitrage extérieur collé

DETAIL A

165° - 180°

015 0295 / 017 0295
019 0295 / 021 0295

180°

015 0295 / 017 0295
019 0295 / 021 0295

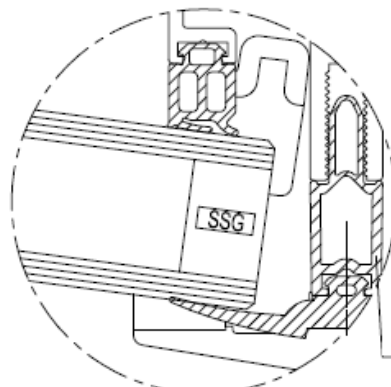

336 0809

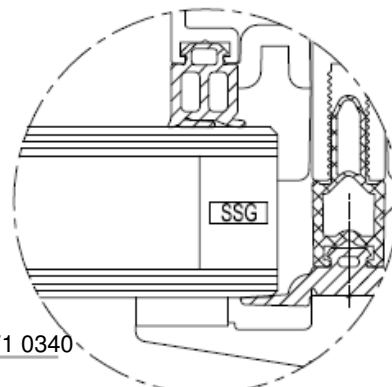

335 0809

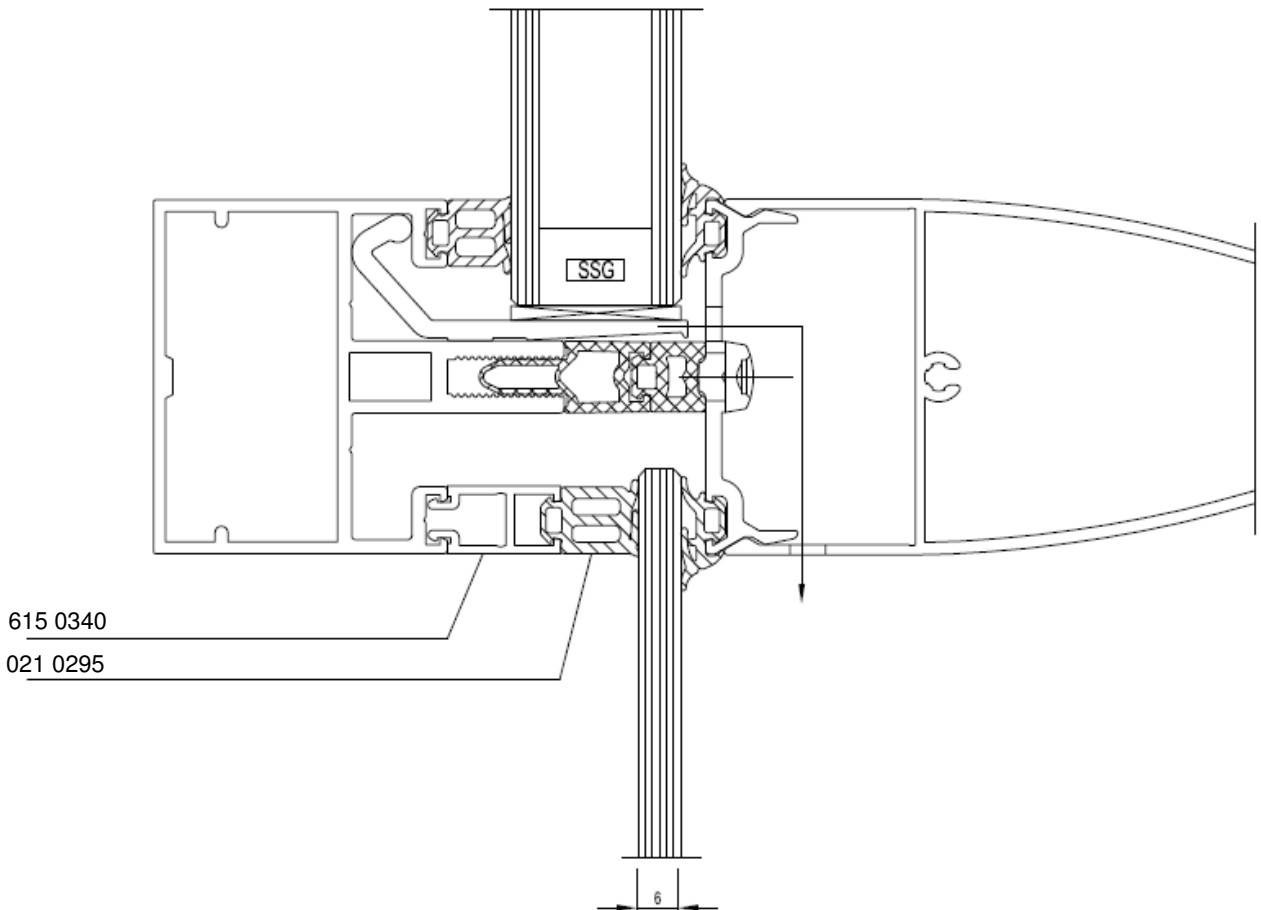
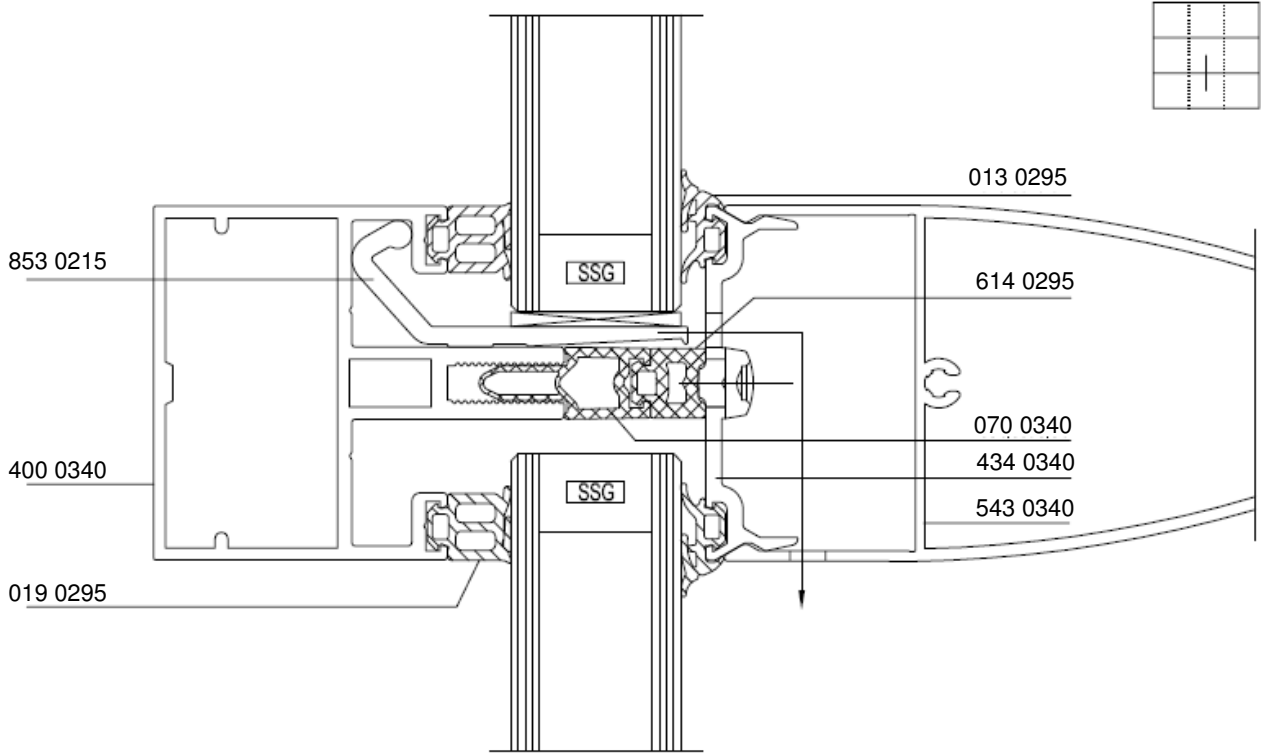

Possibilités d'assemblage

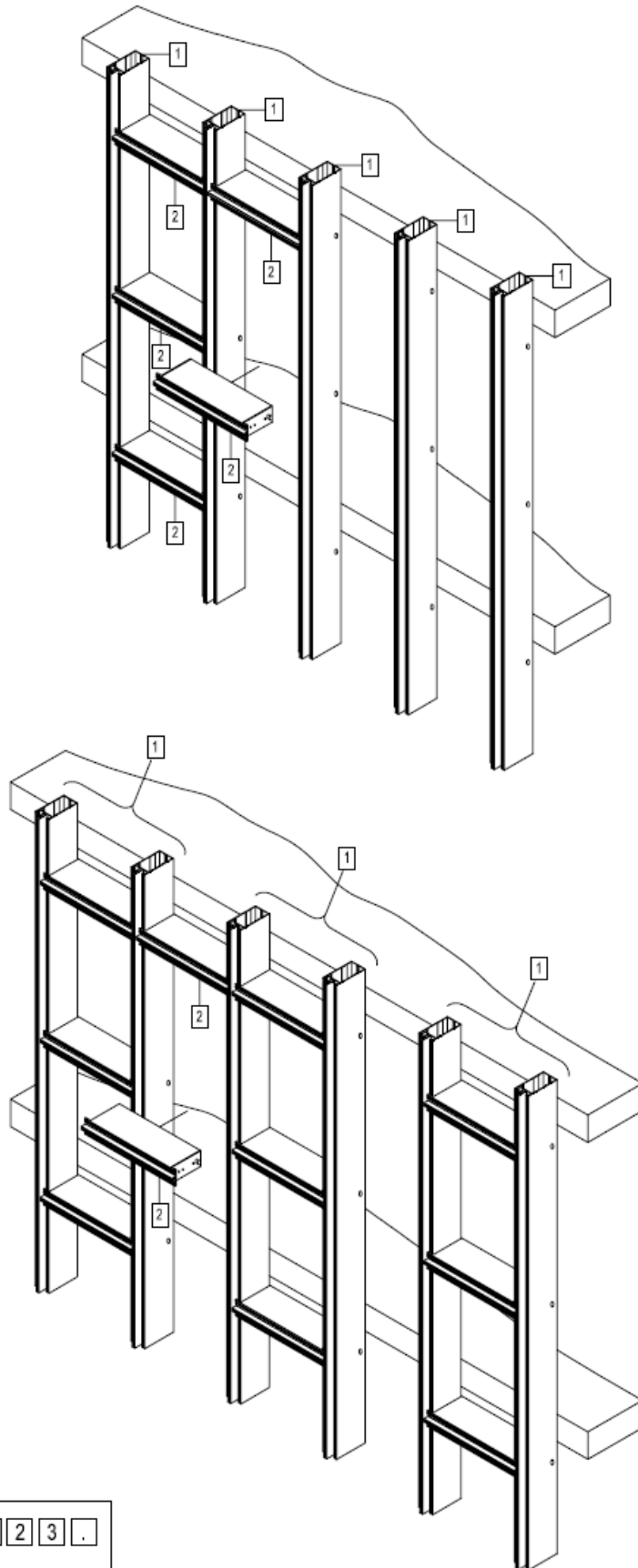

L'ORDRE DE MONTAGE

1 2 3 .

Possibilités d'assemblage

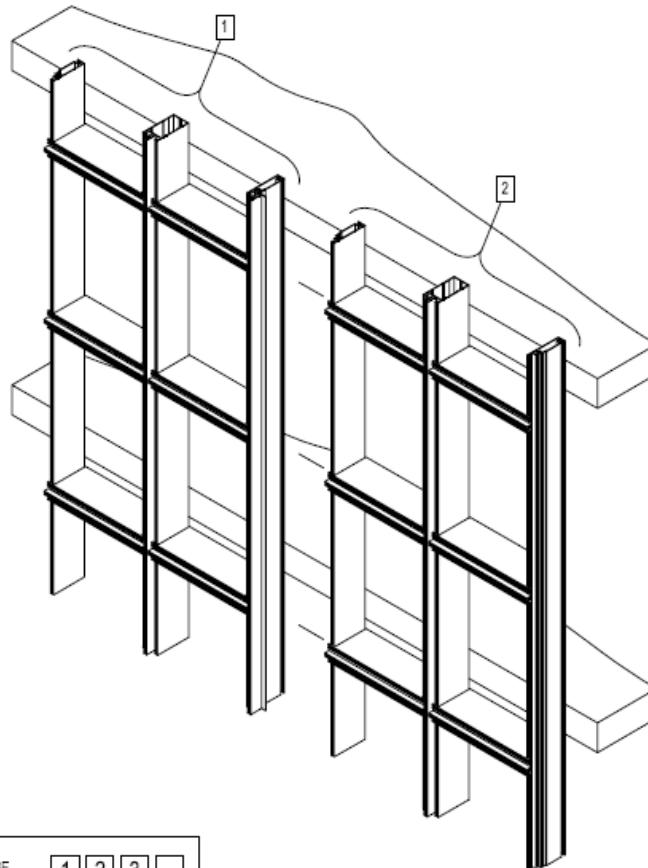
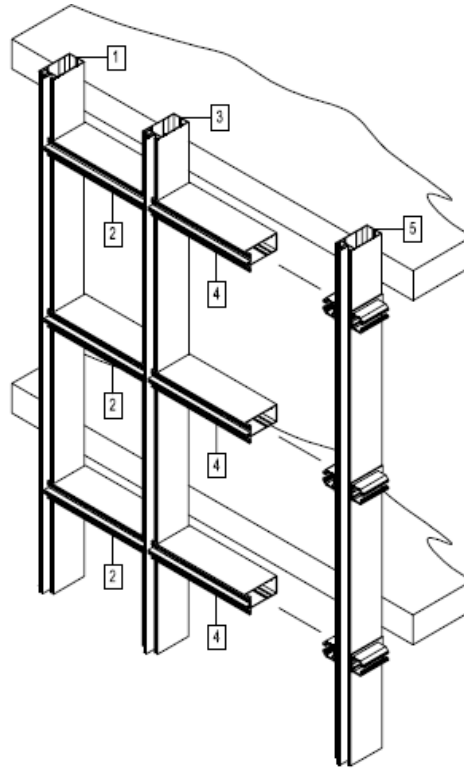

L'ORDRE DE MONTAGE

1	2	3	.
---	---	---	---

Ancrage intermédiaire

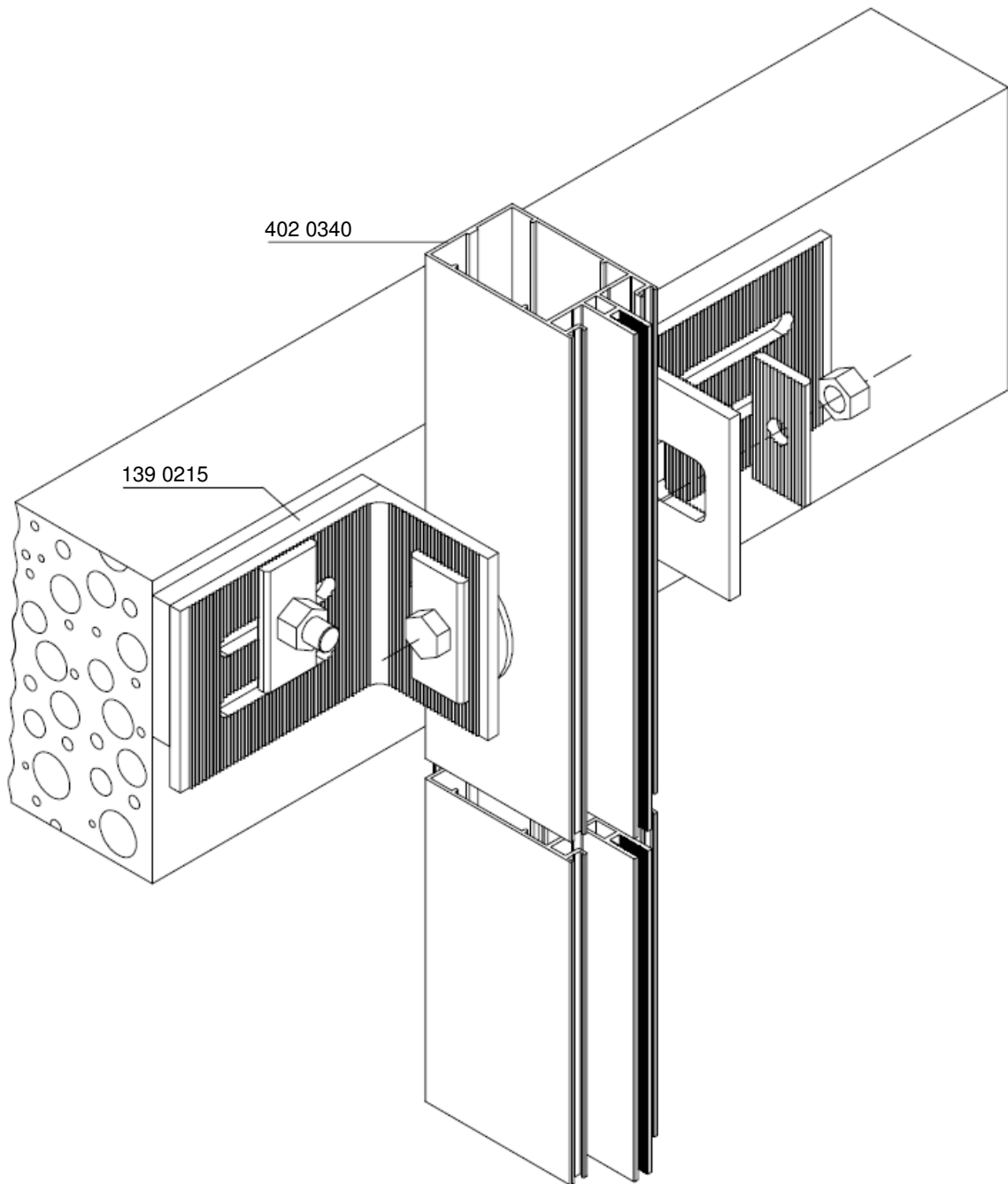

138 0215

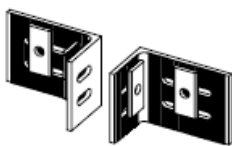

139 0215



140 0215



Ancrage intermédiaire

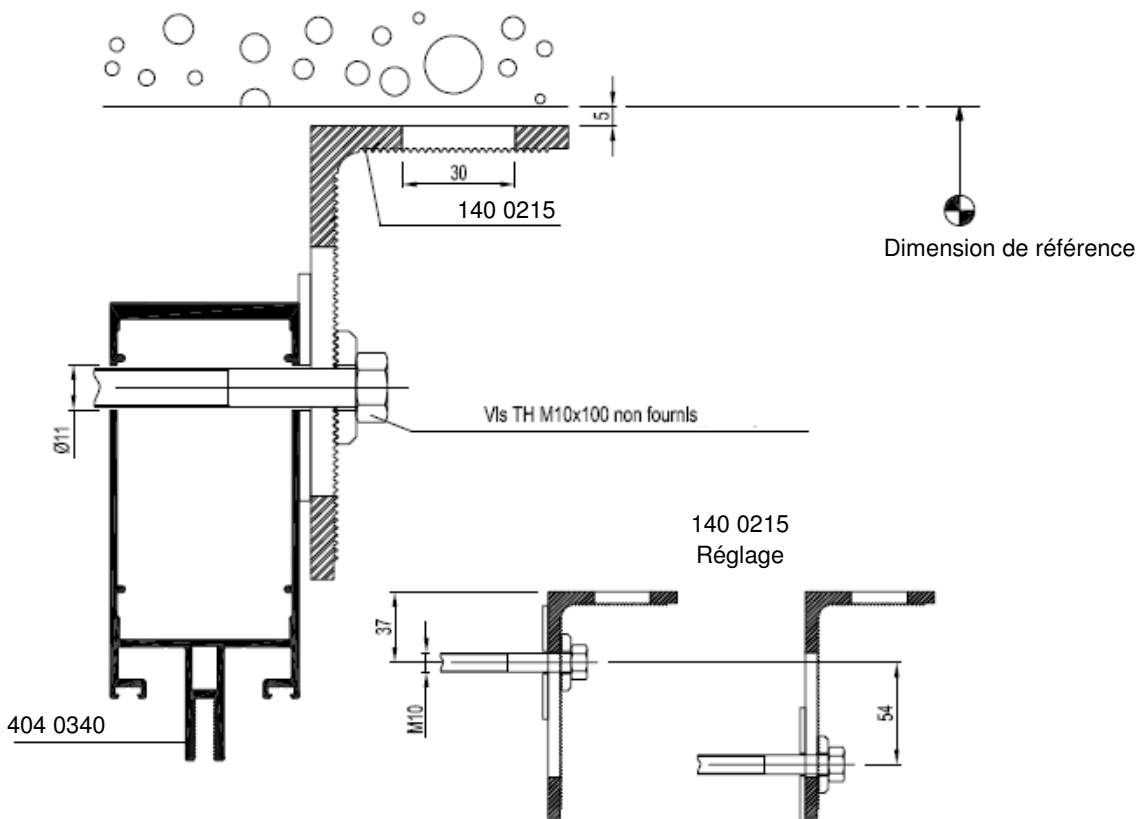
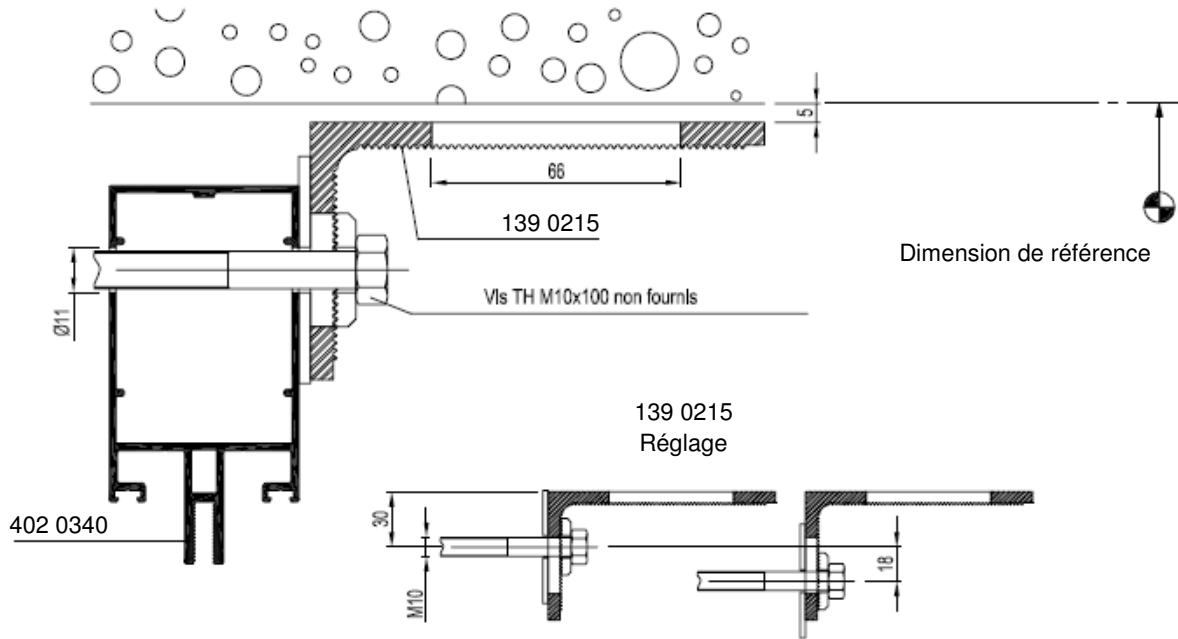

Ancrage intermédiaire

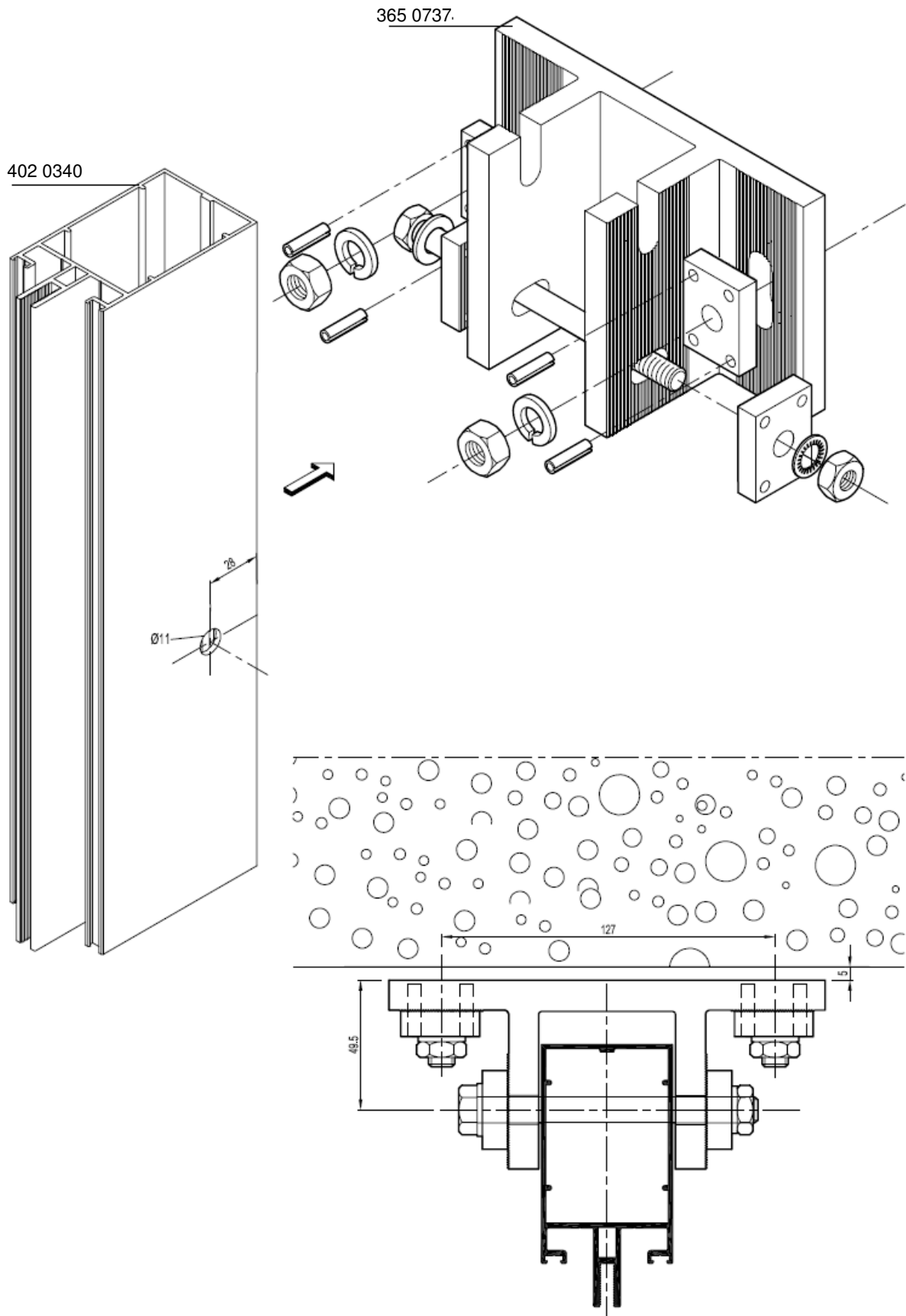

Ancrage intermédiaire

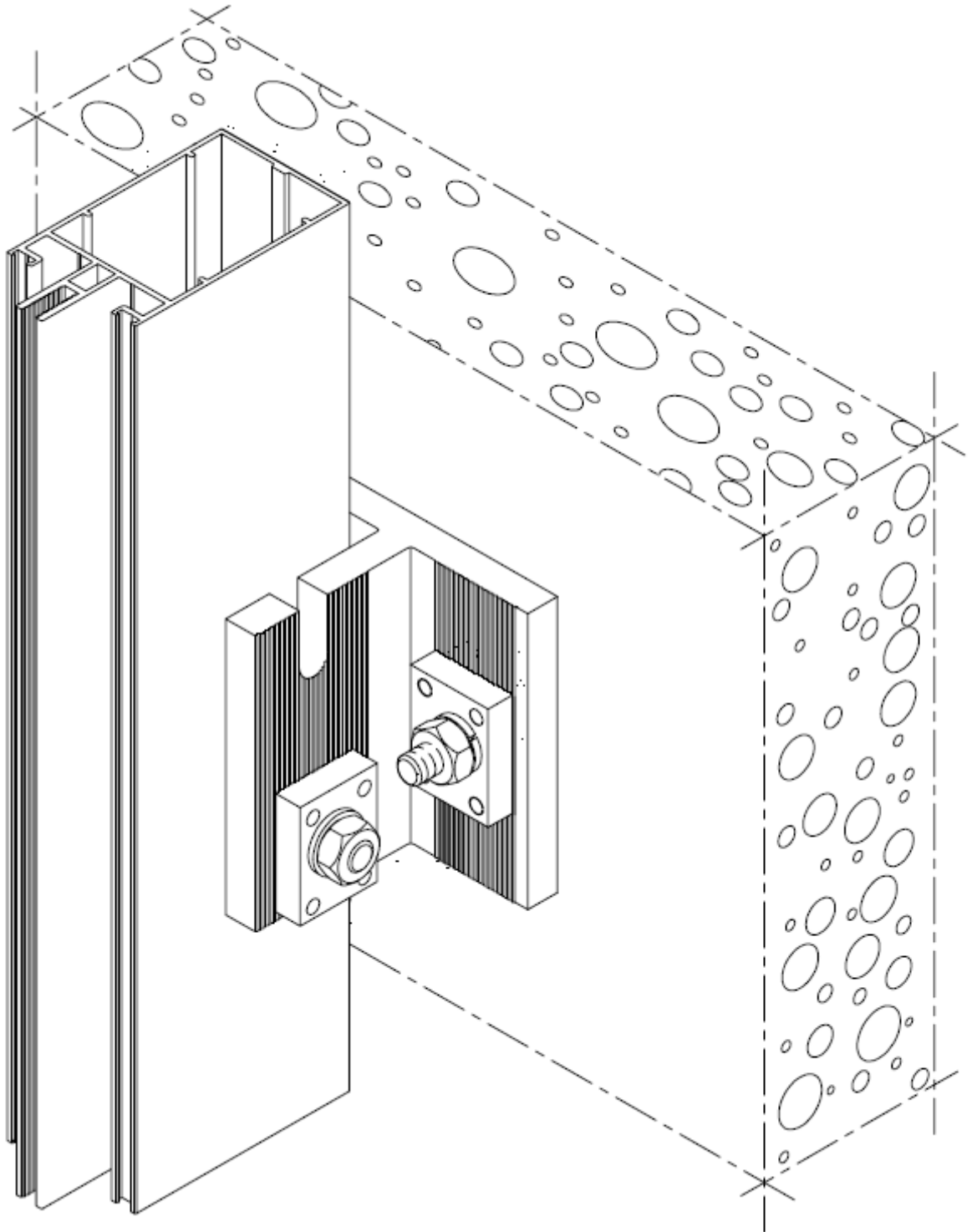

Ancrage intermédiaire

Répartition en fonction des appuis

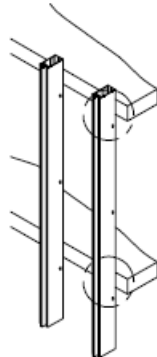

Ancrage au plafond

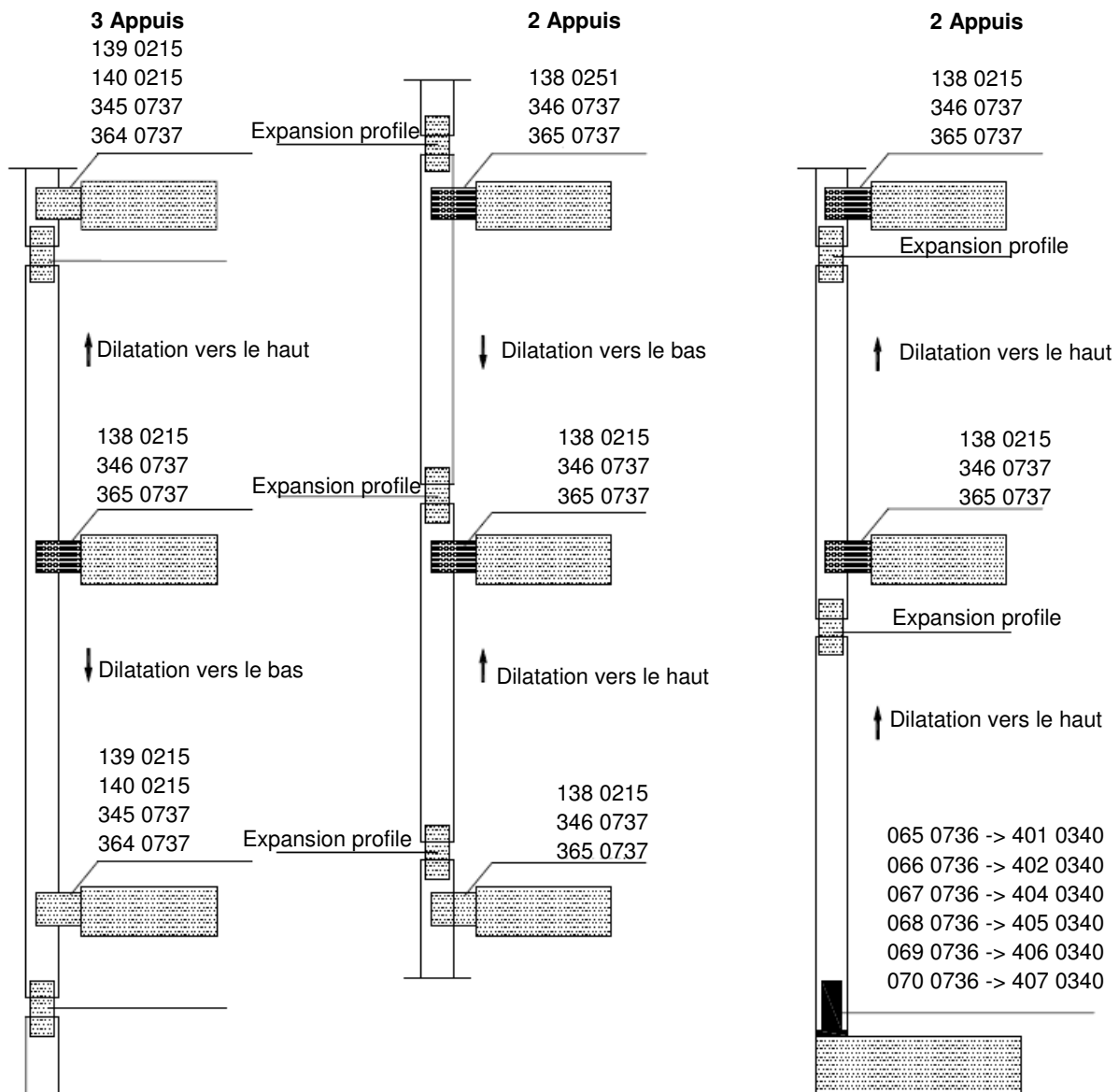
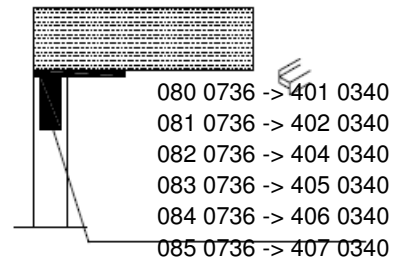

Ancrage au sol

401 0340

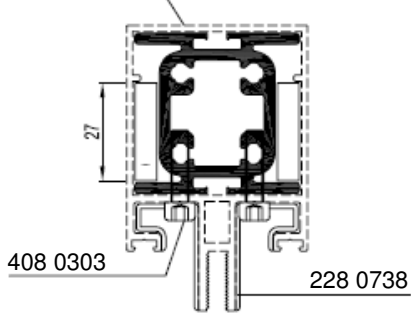

402 0340

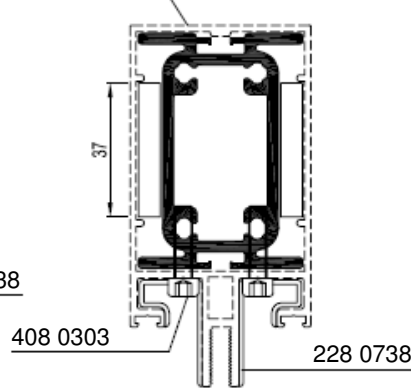

404 0340

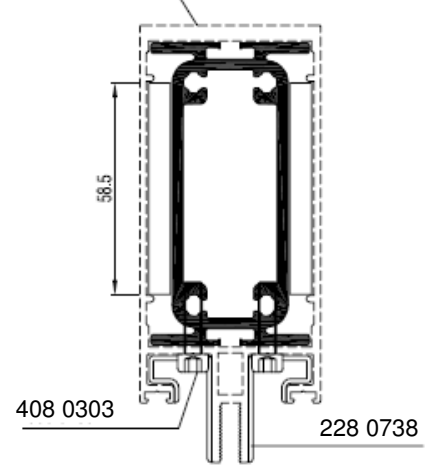

405 0340

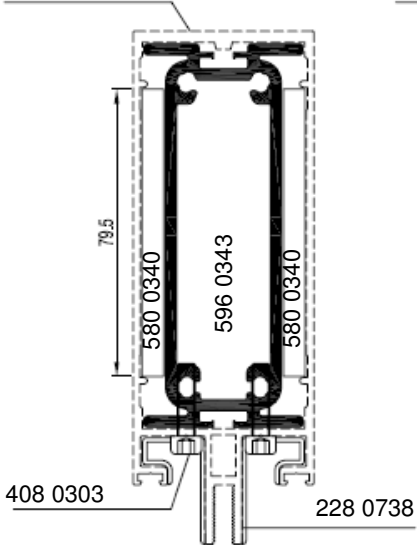

406 0340

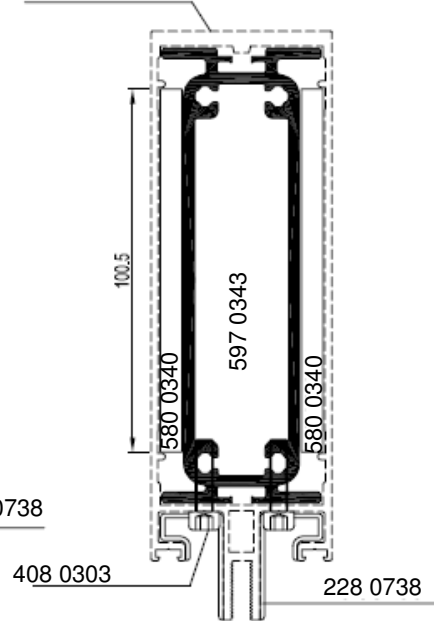

407 0340

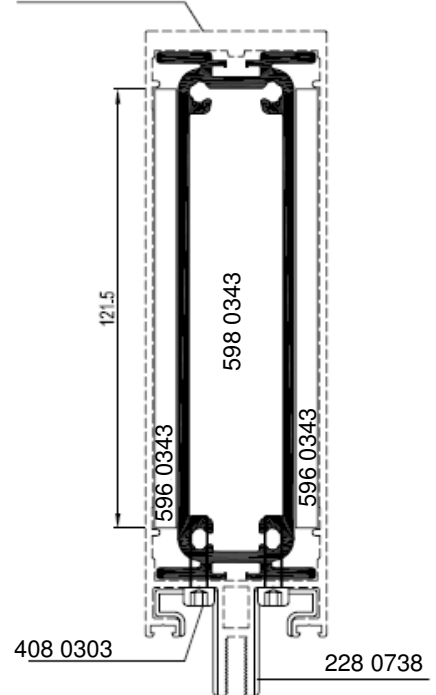

580 0340

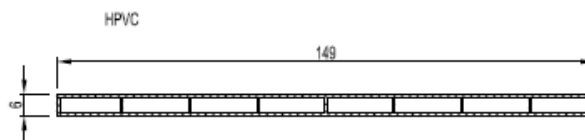

Dilatation

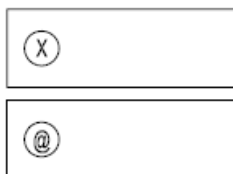
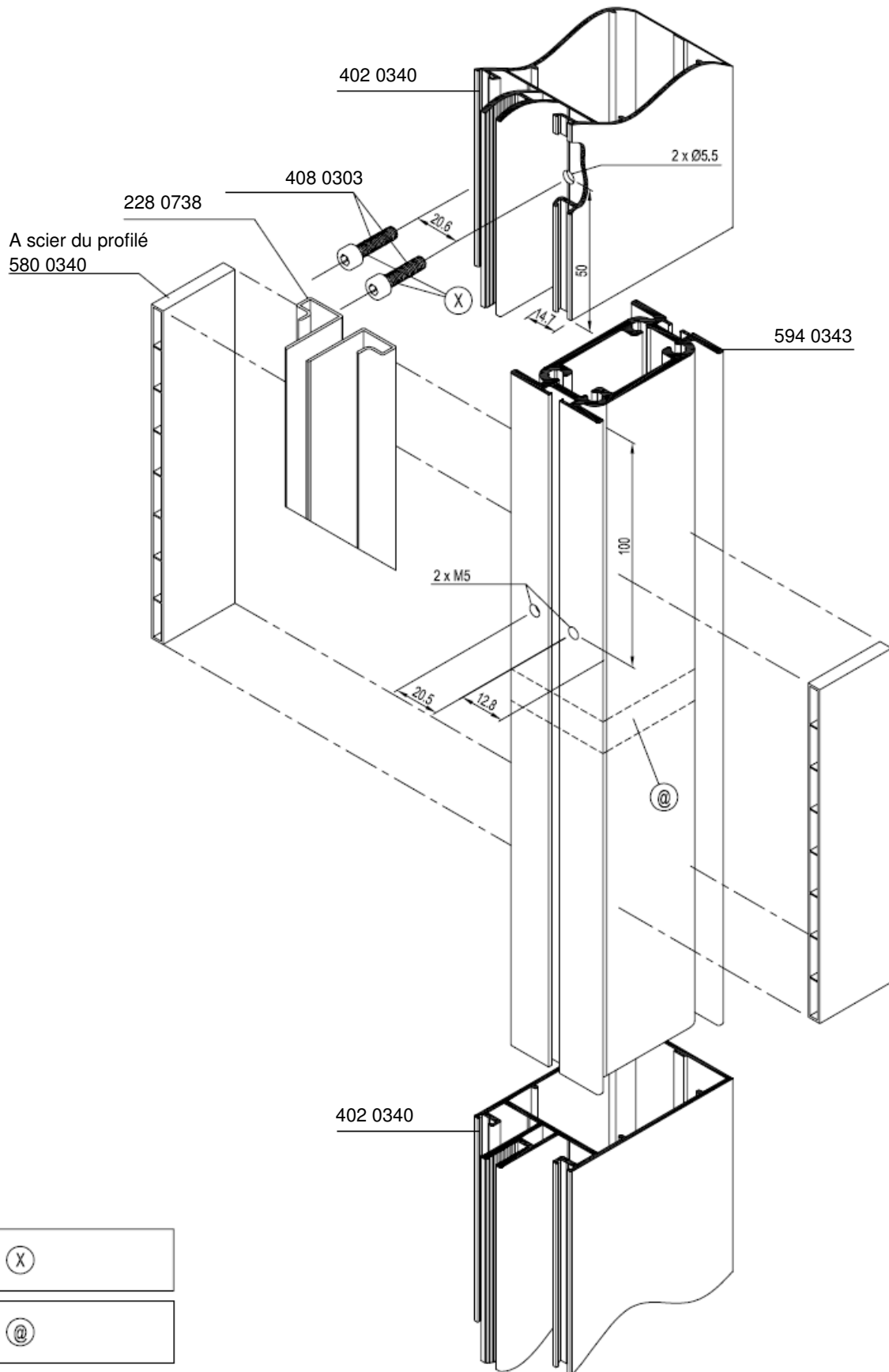

Renfort acier

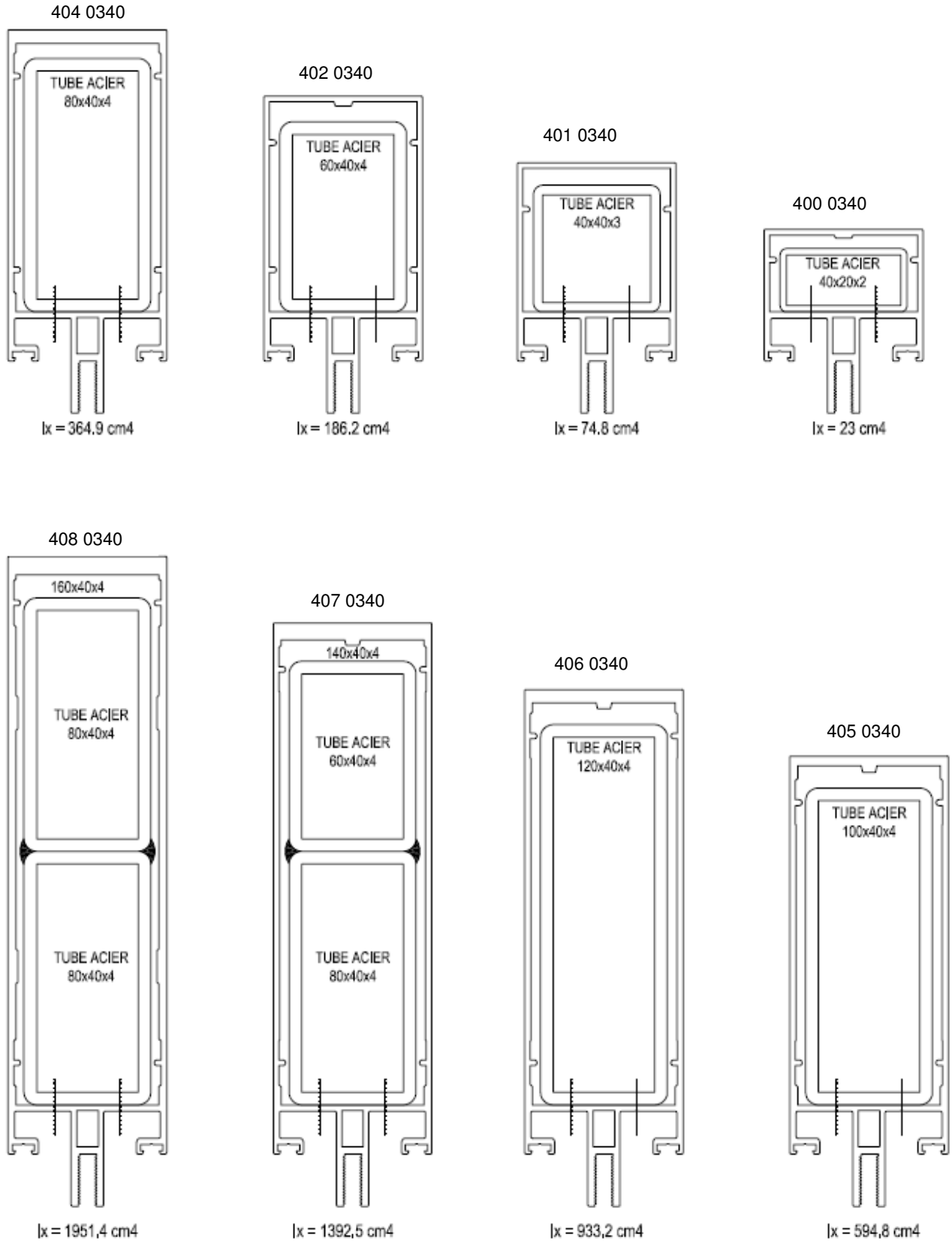

Montage des embouts

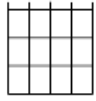

434 0340

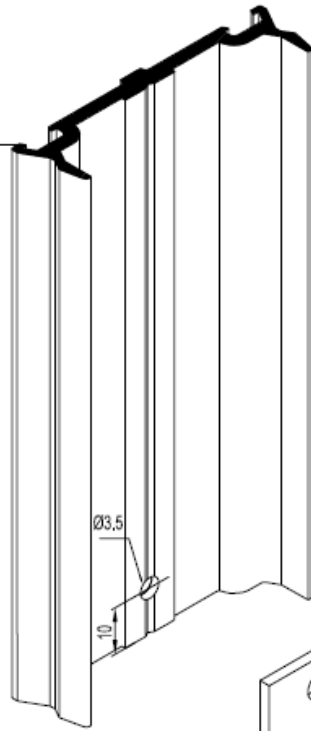

538 0340

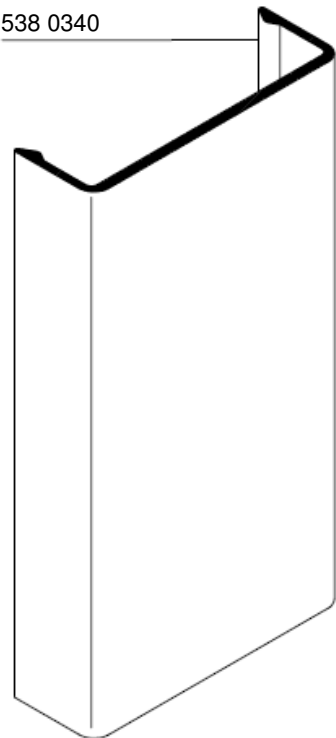

111 0736

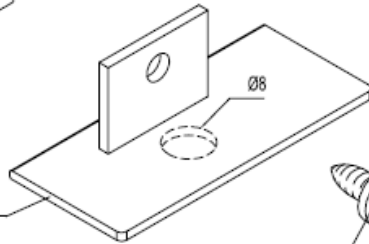

360 0525

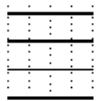

435 0340

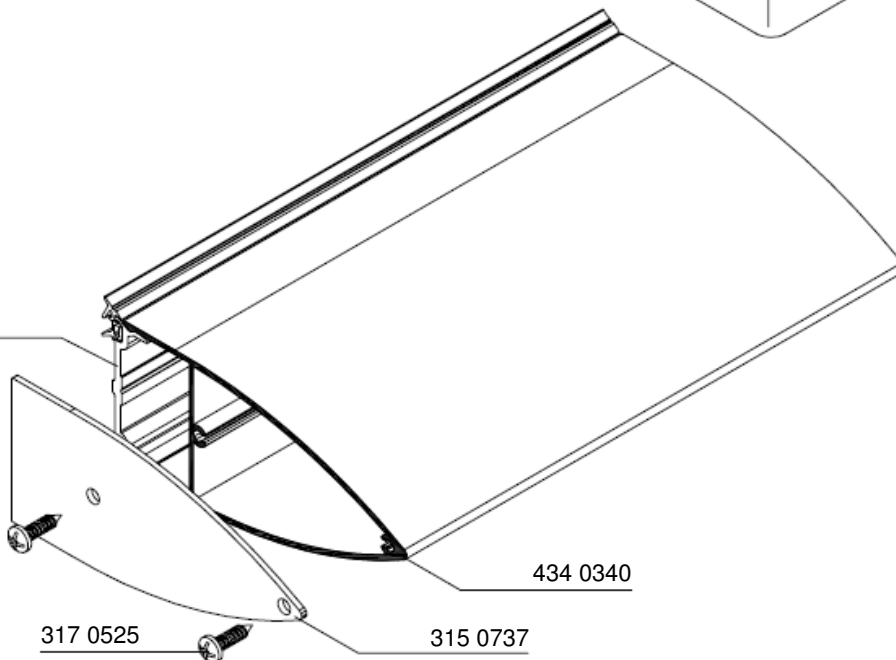

434 0340

317 0525

315 0737

Assemblage traverses

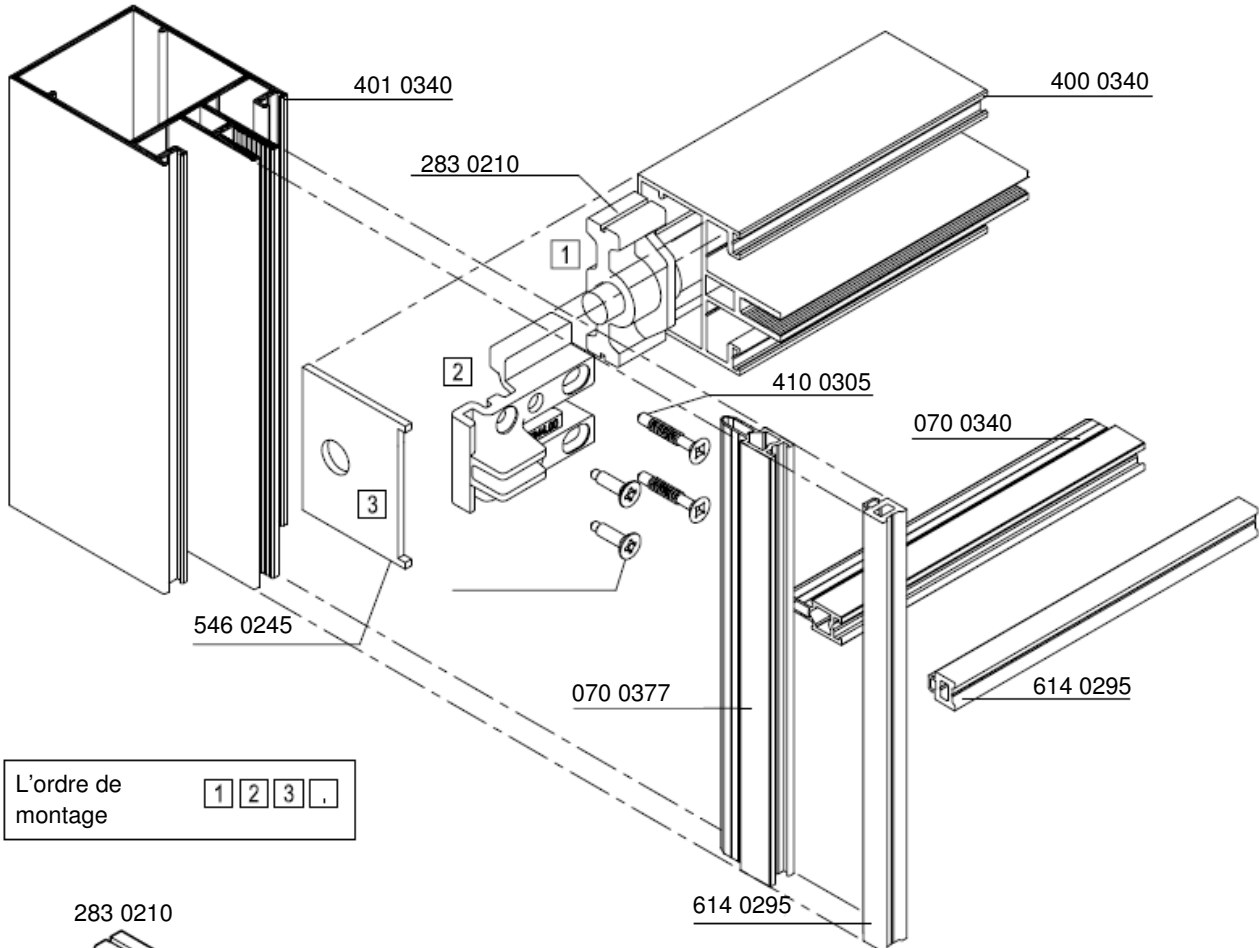

L'ordre de montage

1	2	3	.
---	---	---	---

283 0210



844 0215

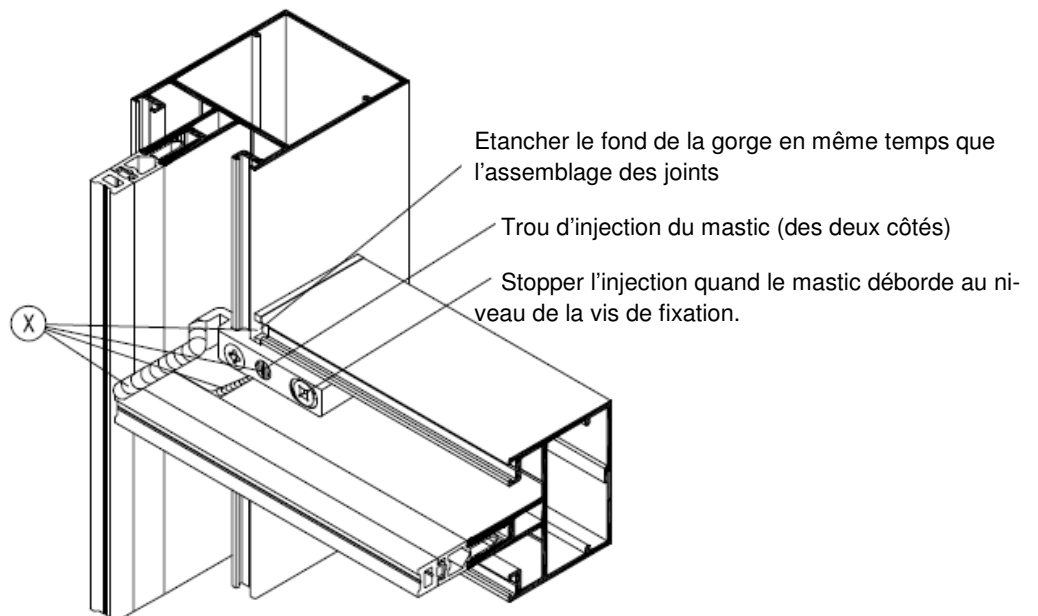
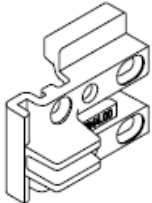

Aperçu trame horizontale

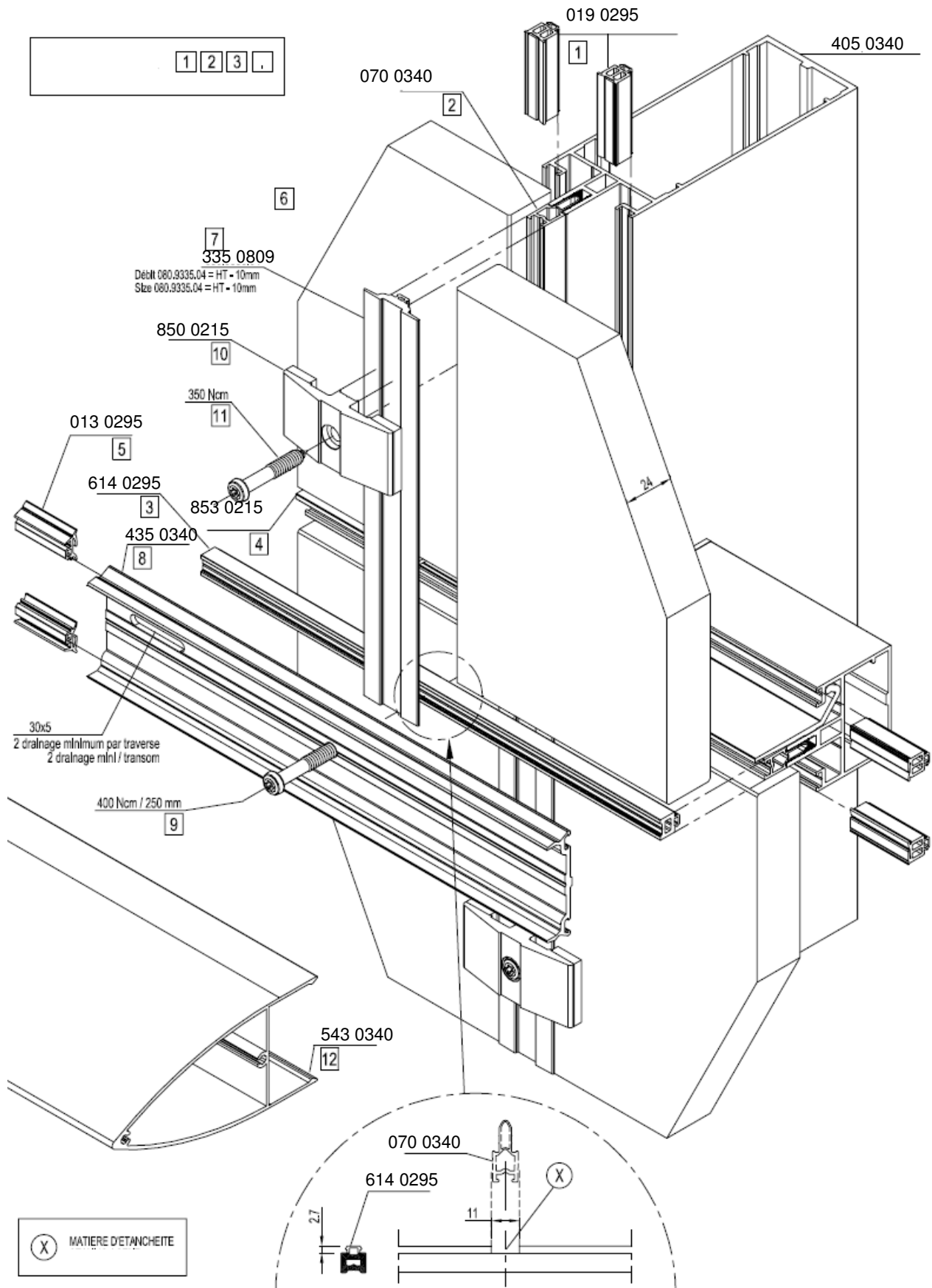

Aperçu trame horizontale

